

Conventional fire detector 9000 series

- **Detector series connectable to all Esser FACP's**
- **Detector series connectable with third-party control panels**
- **All detectors can be combined on common primary line**
- **Up to 30 detectors connectable per detector group**
- **Low quiescent current**
- **Large operating voltage range- Protected against polarity reversal**
- **External series indicator: white print for smoke detectors, green print with white sign for heat detectors**
- **Simplified installation**



Automatic conventional detector with high reliability for mid-sized and smaller objects

The series 9000 automatic limit value detectors are used in objects with smaller and mid-sized amounts of valuable assets. Up to 30 series 9000 fire detectors can be connected to standard groups of fire alarm control panels.

If a detector detects a fire alarm, it is acknowledged by the fire alarm control panel and forwarded to a provider of assistance. In addition, the activated fire alarm is shown by the individual indicator built into each detector.

The series 9000 fire detectors can be connected to all Esser fire alarm control panels. In addition, the series 9000 detectors / type 76xxxx are suitable for operation with fire alarm control panels from other manufacturers.

The alarm current of the detector can be flexibly adjusted for different detector group voltages. For this purpose, the corresponding resistor is incorporated in the detector base. The detectors are available in the following models: optical smoke detectors, fixed heat detectors and rate-of-rise heat detectors.

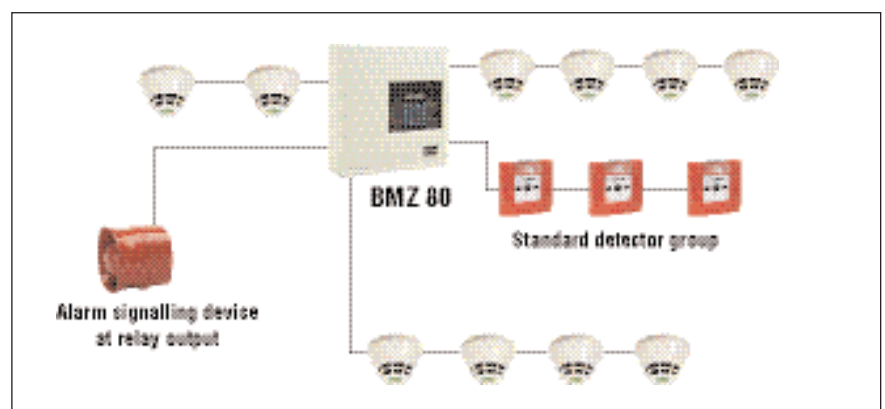

Application example

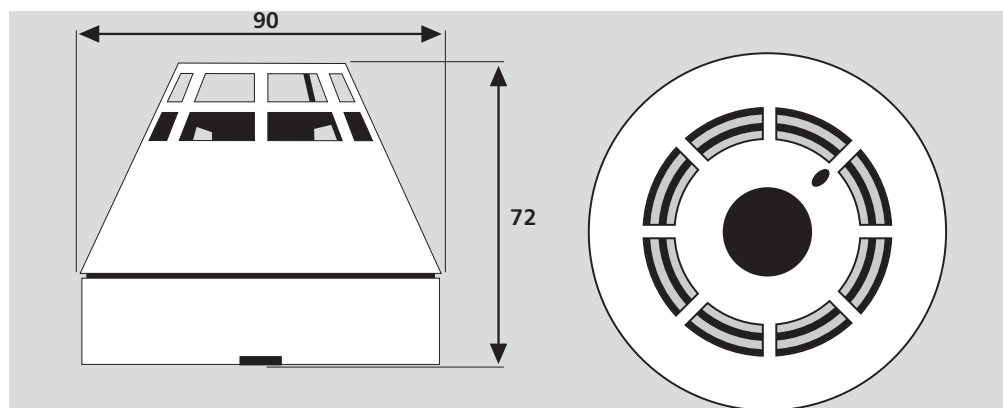

Dimension Drawing (mm)

Technical Data

Type	Fixed heat detector	Rate-of-rise detector	Optical smoke detector
Part No.	761162	761262	761362
Quiescent current	approx. 12 μ A	approx. 12 μ A	approx. 20 μ A, pulsed
Area to be monitored	max. 30 m ²	max. 30 m ²	max. 120 m ²
Mounting high	max. 7,5 m	max. 7,5 m	max. 12 m
Application temperature	-20 °C to +50 °C	-20 °C to +50 °C	-20 °C to +72 °C
Detector specification	EN 54-5 A1	EN 54-5 A1	EN 54-7
VdS approval	G 294003	G 29126	G 29226

General technical data

DC voltage	8 V DC to 28 V DC
Storage temperature	-25 °C to +75 °C
Rel. humidity	max. 95 % rel. humidity, (no condensation)
Type of protection	IP 40
With mounting plate	IP 42
With base adapter surface mount	IP 43
Material	ABS
Colour	white (similar to RAL 9010)
Weight	approx. 90 g
Dimensions (\varnothing x H)	90 x 72 mm (with base)

Order information

	Part No.
Fixed heat detector	761162
Rate-of-rise heat detector	761262
Optical smoke detector	761362
Standard detector base series 9x00	781590
Detector base with relay contact for series 9000	781588
Mounting plate	781495

For further information, please consult the current Fire Alarm Technology catalogue.